



### The Challenge

A turbine Packager in Ohio wanted to reduce the overall size of its current vacuum assisted oil mist eliminator in order to simplify the installation and service processes.

The existing design was excessively tall, which eliminated the service area needed to replace the internal air/oil separator element. Also, the overall size made it difficult to install within the turbine enclosure.

Solberg's challenge was to reduce the overall size of the mist eliminator while handling the required flow and vacuum level.

### The Equipment

**Turbine Model:**

MAN Turbo THM1304-11

**Lube Oil Reservoir:**

600 gallons

**Required Flow Rate:**

120 SCFM

**Required Vacuum Level:** -10" H2O

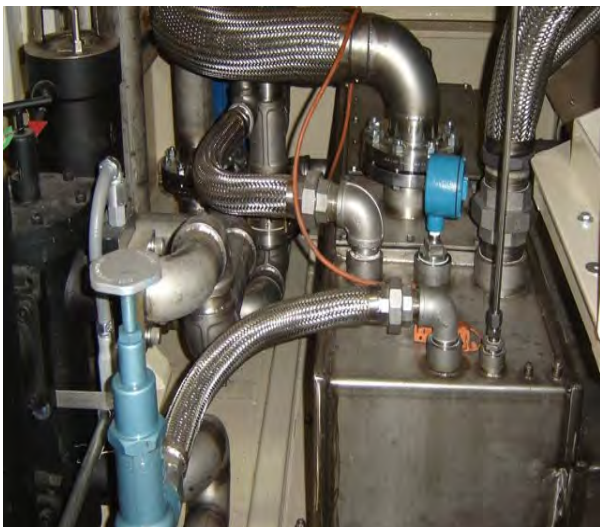

### The Solution

Solberg designed a Vacuum Assisted Oil Mist Eliminator (VAE) to fit onto the vent port of the lube oil reservoir. **(see bottom left photo)** The design resulted from collaboration between Solberg Engineers and the Packager. This unit provided a height reduction of 10", which allowed for easier installation and sufficient service area to replace the air/oil separator element. ***(The photo above demonstrates the importance of overall size. If not customized, maintenance would be difficult in this application.)***

The Packager appreciated the fact that Solberg offered a tailored solution and that multiple options were available to satisfy their needs.

### Installation

The Solberg VAE was specifically built to fit within the turbine enclosure. Solberg consulted with the Packager during their installation process to ensure the proper drain length was used.

# Gas Turbine Package

Compact Design for Easy Installation and Maintenance

## System Components

1. **Internal Air/Oil Separator Element:** 99.97% efficient for .3 micron oil mist. Designed to eliminate visible blow-by emissions
2. **Regenerative Blower:** Creates vacuum to overcome differential pressure created by the separator element and to maintain negative pressure in the lube oil reservoir.
3. **Vacuum Gauge:** Allows the end-user to monitor the vacuum level produced by the Solberg VAE, so the proper level is maintained in the lube oil reservoir.
4. **Oil Return Drain:** This drain runs back to the lube oil reservoir. To ensure proper drainage, the line is submerged below the low oil level.

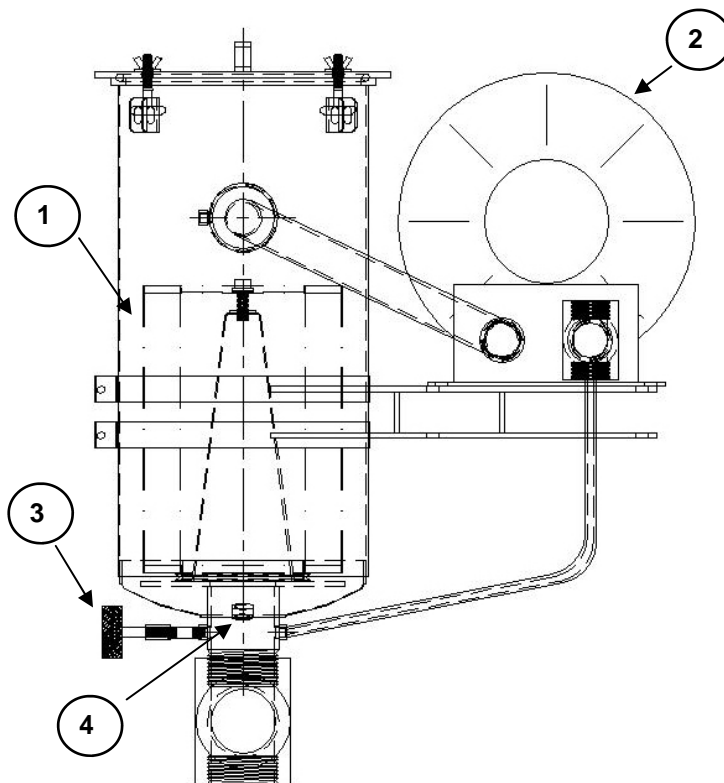

## Results

The Solberg VAE was installed in Ohio and the complete turbine package was shipped to an end-user in Trinidad. The VAE performance has met the expectations of the Packager and final customer.

